

SHENGWEI 胜为[®]

胜为产品规格书



深圳市创新胜为科技有限公司

Shenzhen Innovation Shengwei Technology Co., Ltd.

深圳市创新胜为科技有限公司

(产品承认书)

客户名称:

Customer :

客户料号:

Customer P/N : WHC4010G

品名:

Part Name : 胜为 HDMI2.0连接线 红色铝壳改款 WHC4010G 1米

规格:

Speciflction : HDMI A TO A 30awg 19+1BC OD :7.0mm 4K@60hz PVC 1米

厂商名称:

Vendorse Name: 深圳市创新胜为科技有限公司

电话:

传真:

Phone :

Fax :

地址:

Address

邮箱:

E-mail :

日期

版本:

Date :

2022/8/31

Edition :

A/0

胜为确认

客户确认

深圳市创新胜为科技有限公司

目录

内容	页数
封面	P1
目录	P2
成品图纸	P3
线材规格书	P4
成品包装	P5
HDMI公接头图纸	P6
HDMI公 马口铁	P7
防尘帽	P8
盐雾报告	P9
插拔力测试	P10
摇摆测试	P11
影音测试	P12
磨砂袋图纸	P13
纸箱图纸	P14

变更版式	变更内容	变更时间	变更人
A/0	新版发行	2022-08-26	

料号: WHC4010G

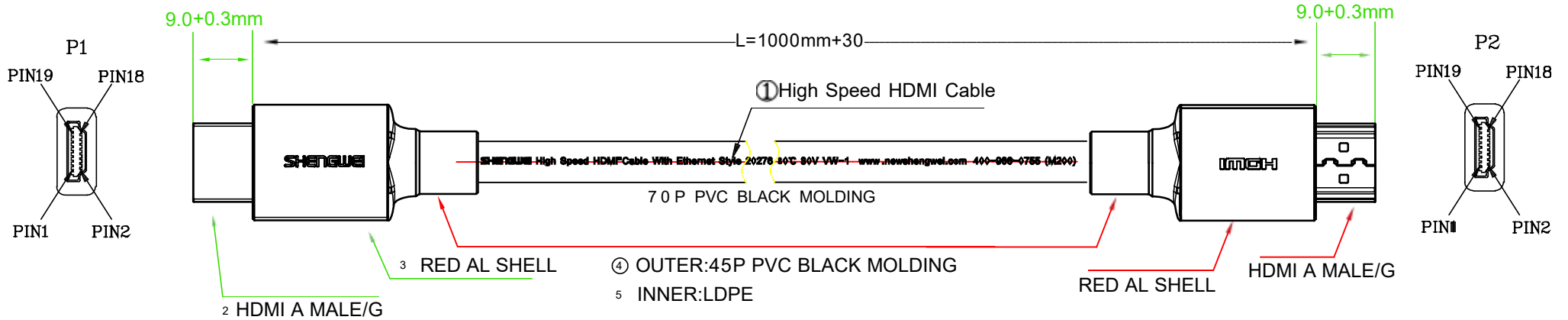

测试条件:

- 100%开路, 短路和错位测试;
- 导通阻抗: 3欧姆最大;
- 绝缘阻抗: 5兆欧姆最小/DC300V/10MS;
- 产品需过电视分辨率为: 3840*2160 60hz 测试;
- 产品生产时按批次做可信赖性测试, 并出具报告;
- 产品首次生产时需做线材高频测试, 并按3个月为周期提供报告;
- 产品按月度做分解测试, 并出具报告;
- 产品需要符合基础环保要求, 并到达一定防火等级;

7	SW磨砂胶袋180*255mm*10cc	PCS	1
6	胜为铁金扎带	PCS	2
5	INNER: LDPE	g	3
4	OUTER :45P PVC BLACK MOLDING	g	3
3	RED AL SHELL	PCS	2
2	HDMI A MALE/G 20PIN 铁壳红色胶芯	PCS	2
1	30AWG[0.254BC/FOAM*1P+0.254BC/HDPE+AL]*5P+(0.254BC/HDPE*4C+AL+D/0.254BC+B128/0.12AM OD:7.0MM BLACK 全雾PVC]	mm	1000
NO	规格说明	单位	用量

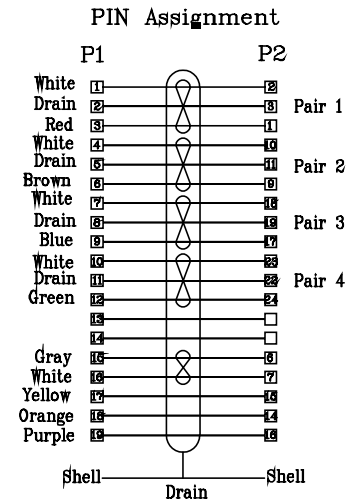
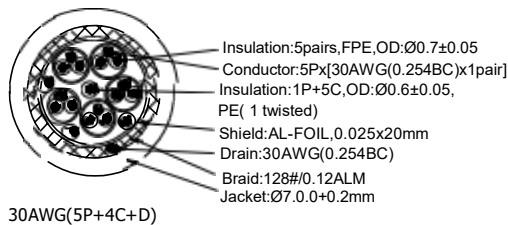

日期	制图	审核	标准
22-08-26			
单位: mm	比例: NON	版次: A/0	

深圳市创新胜为科技有限公司

品名:
深圳市创新胜为科技有限公司
HDMI A/M TO A/M WHC4010G

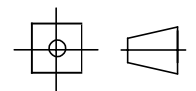

lof1

深圳市创新胜为科技有限公司

线材工艺

第 1 页

CABLE CONSTRUCTION (电线结构)

产品型号	HDMI 30AWG 19+1	文件图号	MZ-1001	版本	V/1
产品规格	(1/0.254BC*1P+D+AL)*5+1/0.254BC*4C+B+AL			发行日期	2022/6/6
Construction Item	结构项目	结构项目A		结构项目B	结构项目C
芯线	构造线规	AWG	30 AWG	30 AWG	30 AWG
	导体尺寸	mm	1/0.254BC±0.003	1/0.254BC±0.003	1/0.254BC±0.003
	绝缘材质	--	FPE-Skin-PE	HDPE	HDPE
	芯线线径	mm	0.70±0.02mm	0.6±0.02mm	0.6±0.02mm
	静电容量	pf/m	98±1pf/m	--	--
	偏心度	%	≥90%	≥90%	≥90%
	押出方式	--	充实 (solid)	充实 (solid)	充实 (solid)
颜色	--	绿 白	透明	红 白 绿 黄	

对绞	绞向	--	右 (right)	导体尺寸	mm	1/0.254mm BC(裸铜丝)
	绞距	mm	18mm	构造线规	AWG	30 AWG
	绞合外径	mm	1.55mm	导电面	--	向内
	包带方式	--	绕包	包带铝箔	mm	8mm*25 μ
	重叠率	--	30%	铝箔颜色	红、兰、绿、金、银	
备注：《对绞时须加（透明地线）在里面，生产时请注意》						

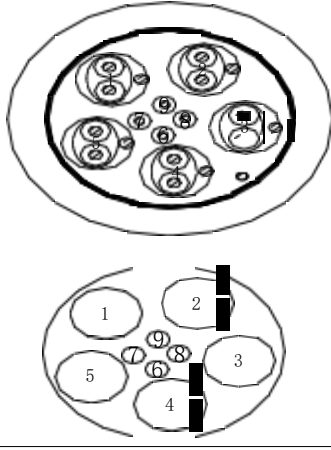
成缆	绞向	--	右		成缆排位如下：	
	绞距	mm	100mm		1. 绿*白 红	
	绞合外径	mm	4.1mm		2. 绿*白 金	
	包扎方式	--	拖包		3. 绿*白 兰	
	包扎方向	--	右		4. 绿*白 绿	
	导电面	--	(向内)		5. 绿*白 银	
	铝箔颜色	--	兰色		6. 红	
	成缆铝箔	mm	20mm*20 μ		7. 白	
	重叠率	%	34%		8. 黄	
	外径	mm	4.3mm		9. 绿	
	构造线规	AWG	30AWG			
	成缆地线	mm	1/0.254BC			
备注：《成缆时须加（1/0.254CCS）地线在里面》						

押出	押出材质	--	PVC 70P半雾面
	成品线径	mm	7.0±0.2mm
	平均厚度	mm	1.55±0.05mm
	押出方式	--	(半管稍紧)
	外观	--	半雾面哑光
	颜色	--	黑
	印字内容		SHENGWEI High Speed HDMICable With Ethernet Style 20276 80° C 30V VW-1 www.newshengwei.com 400-966-0755 (MZ200)
印字颜色	白色		
备注：《具体押出材质、押出颜色以生产指令单为准》			

核 准		审 核	
-----	--	-----	--

产品	规格	胶袋尺寸	装袋数量	中胶袋尺寸	装袋数量	防水胶袋尺寸	纸箱尺寸	装箱数量	胶袋标签尺寸	外箱标签尺寸
WHC4010G		180*255mm	1PCS	60*50cm	20PCS	90*80cm	42*38*33cm	100PCS	40*30mm	100*100mm
WHC4015G		180*255mm	1PCS	60*50cm	20PCS	90*80cm	42*38*33cm	100PCS	40*30mm	100*100mm
WHC4020G		180*255mm	1PCS	60*50cm	20PCS	90*80cm	42*38*33cm	100PCS	40*30mm	100*100mm
WHC4030G		220*300mm	1PCS	60*50cm	20PCS	90*80cm	42*38*33cm	80PCS	40*30mm	100*100mm
WHC4050G		220*300mm	1PCS	60*50cm	20PCS	90*80cm	42*38*33cm	60PCS	40*30mm	100*100mm

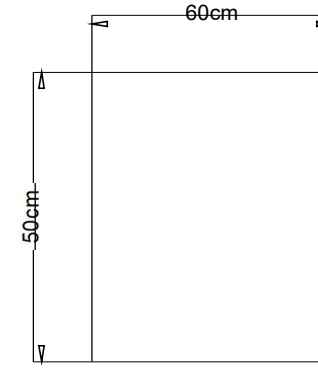

3 中胶袋

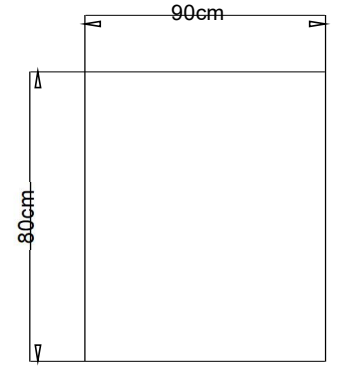

4 防水胶袋

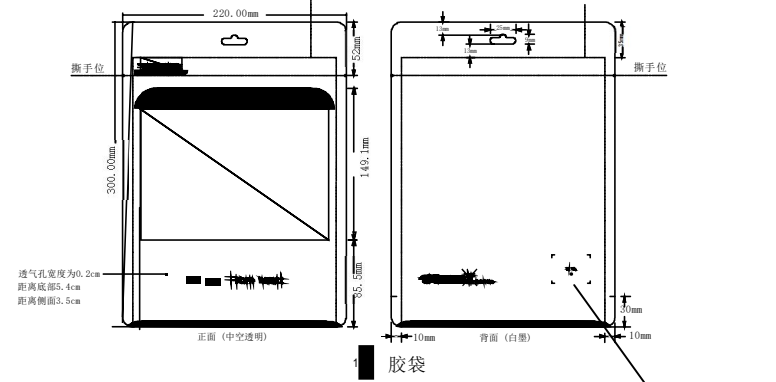

1 胶袋

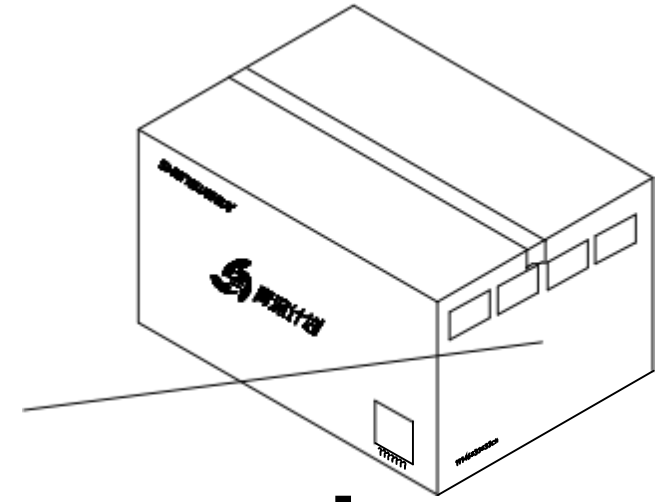
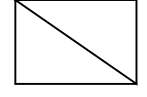
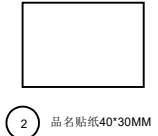

11											
10											
9											
8											
7								1/X	SET		
6	外箱标签	100*100mm 白底黑字						1/X	SET		
5	纸箱	420*380*330mm 印刷黑色+绿色 (青流计划, 胜为-logo字样)						1/X	SET		
4	防水袋	80*90cm						1	SET		
3	内PE袋	60*50cm						1	SET		
2	产品标签	40*30mm 铜版纸不干胶 白底黑字						1	SET		
1	磨砂袋	180*220mm						1	SET		
ITEM	NAME	DESCRIPTION					Q'TY	UNIT			

X,± 1	X,*± 1	Customer P/N:		
.X± 0.3	.X*±			
.XX± 0.20	.XX*±			
.XXX± 0.100	.XXX*±	DOCUMENT NO.:		
UNITS:	mm	TITLE:		
TEST DRAWINGS AND SPECIFICATIONS ARE THE PROPERTY OF WIDER CABLE AND SHALL NOT BE REPRODUCED COPIED OR CUED IN ANY MANNER WITHOUT THE PRIOR WRITTEN CONSENT OF WIDER CABLE.		APPD:		
		CHKD:		
DRAW: wanglvxiao		Customer Name: 胜为		
		SCALE	Pages	REV.
		1:1	2/2	A

ROHS

记号	日期	更改内容	核定者	核准
△	2016-02-23	外壳铜压20PIN端子处改为凸包压平的方式。	龚文贤	蒋复明

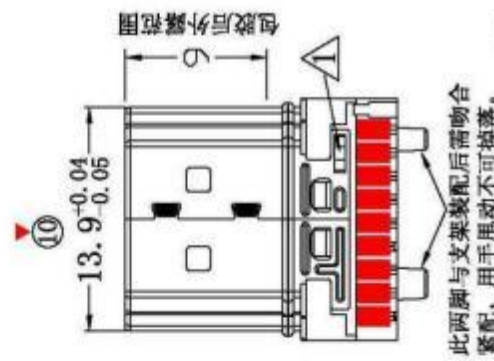
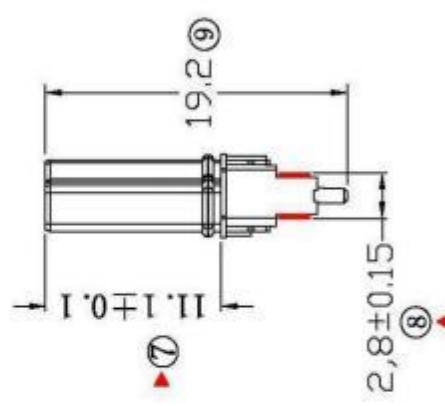
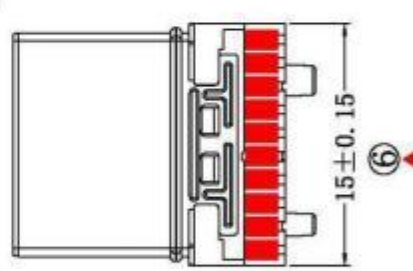
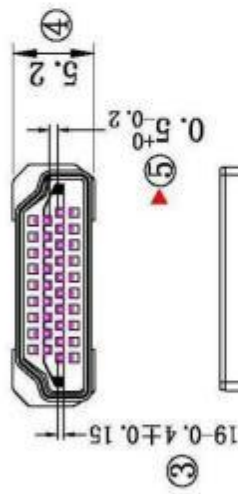

此两脚与支架装配后需吻合
紧配, 用手甩动不可掉落。

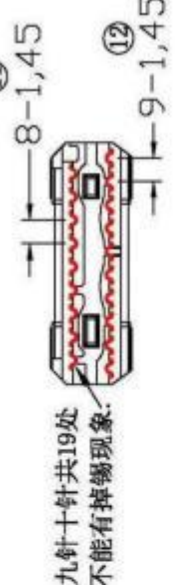

九针十针共19处
不能有掉锡现象。

- 注:
1. 未标示公差之尺寸依照一般公差。
 2. 标有 ▲ 的尺寸为重点检验尺寸。
 3. 4.45和13.9尺寸只量包胶后外露范围。
 4. PIN针端子电镀为半金半锡。

产品特性:

1. 插入力/拔出力: 与HDMI A头母座对插, 插入力最大 4.5Kgf, 拔出力在1Kg-4Kgf内。
2. 插拔次数: 与HDMI A头母座对插对插10000次, 插头接触电阻变化值插拔之前30mΩ max, 插拔后50mΩ max。
3. 绝缘强度: 单独连接器测试(两相邻端子或接地), AC 500V 不能击穿; 绝缘阻抗: 单独连接器测试(两相邻端子或接地), 施加DC 500V 最小100MΩ。
4. 铁壳盐雾测试>24H, PIN针镀金区盐雾测试>24H。

NO	零件名称	数量	简要资料
4	锡	20PCS	直径0.7无铅锡丝, 含银含量2.0%
3	PIN针端子	19PCS	C5191 HV200-220度 T=0.2mm 铜底>60μ 镀80-100μ, 全GFP
2	铁壳	1PCS	SPCC HV110-140度 T=0.28mm 铜底>1000μ 镀80-100μ
1	前后盖胶芯	各1PCS	LCP BLACK
			表面处理

核准	审核	制图	材料:	品名:	HDMI-铁壳A款-镀镍-加锡
	龚文贤	/	表面处理:	料号:	
			单位:	日期:	
			比例:	2016.04.05	
一般公差					版本
0~10	±0.1				A1
>10~50	±0.15				
>50~100	±0.2				
>100~	±0.3				
	ANGULAR	±2°			

GP Component

REV.	ECN NO.	LOCATIONS	DESCRIPTION	DATE	DESIGN
A0			原始版本(INITIAL EDITION)	2021.05.21	曾勇

上盖图

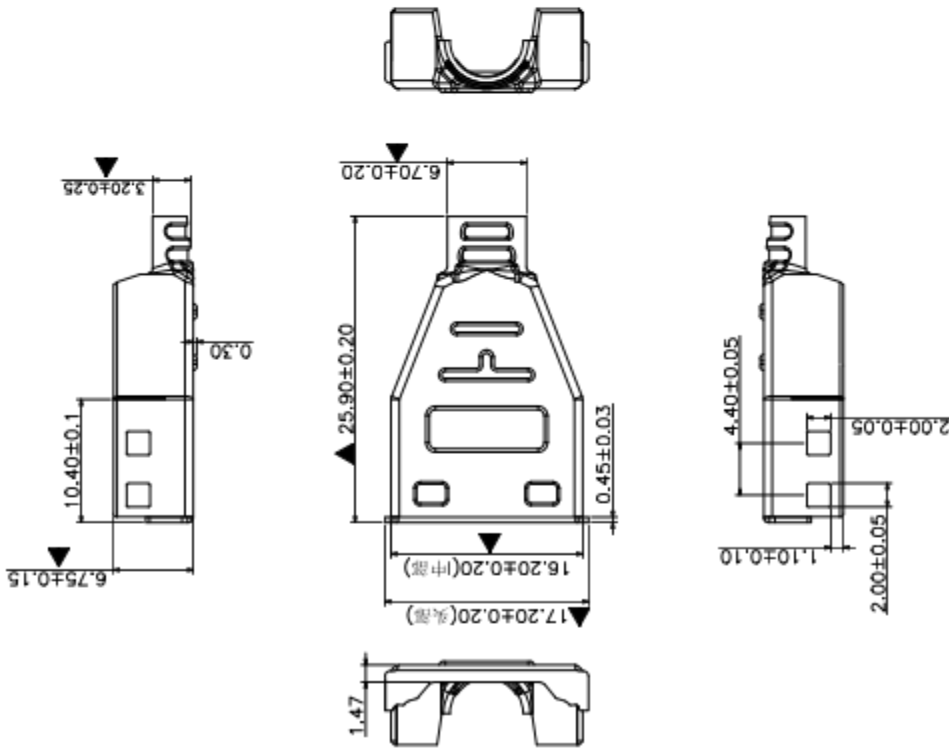

下盖图

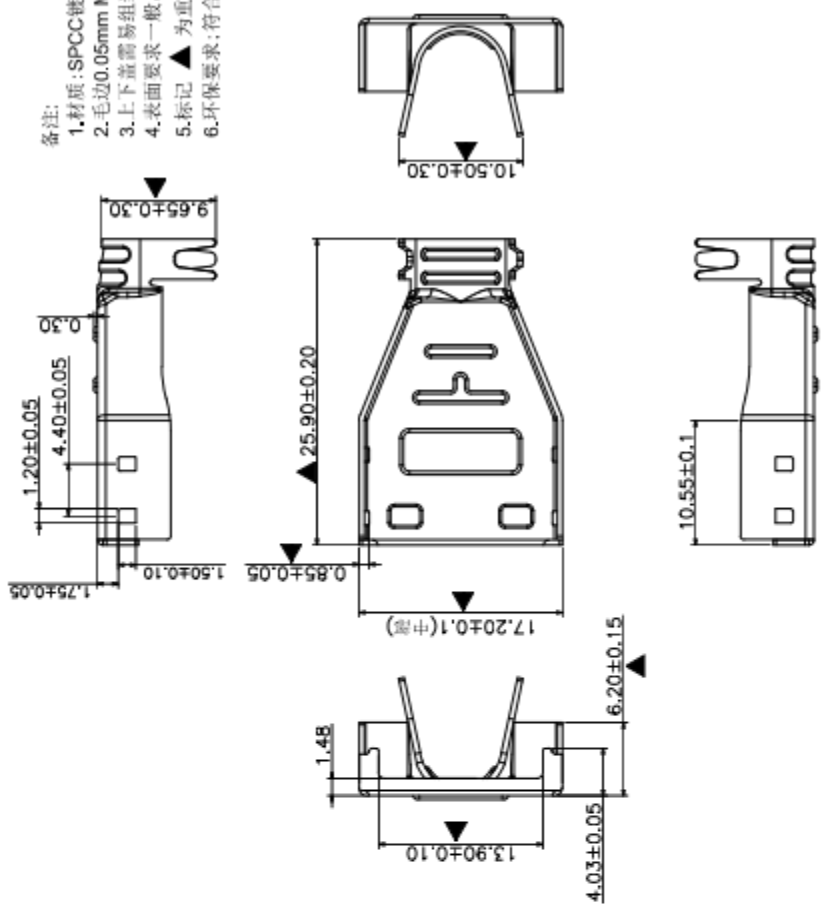

- 备注:
- 1.材质:SPCC镀锌板, T=0.40mm.
 - 2.毛边0.05mm MAX.
 - 3.上下盖需易组装, 不能轻易脱离.
 - 4.表面要求一般, 需做防锈处理.
 - 5.标记 ▲ 为重点管控尺寸.
 - 6.环保要求;符合ROSH标准.

TABLE

品名规格	产品料号
HDMI 屏蔽壳-上盖	KS-T231
HDMI 屏蔽壳-下盖 带铆爪	KS-T232

TOLERANCE:	40.30
X.	50.25
X.K	50.20
X.KX	50.15
X.KXX	50.10
X*.K*	X.K* ±1*

DESIGN BY:	曾勇	DATE:	2021.05.21
CHECKED BY:	唐元武	DATE:	2021.05.21
APPROVED BY:	袁爱祥	DATE:	2021.05.21

PART NAME:		HDMI 屏蔽壳-H款上下盖
PART NO.	SEE TABLE	
MOLD NO.	NA	
DRAW NO.	NA	
SHEET NO.	01 OF 01	

▲ = 13

UNIT: mm (inch)	SCALE: 3:1	SIZE: A1
-----------------	------------	----------

RoHS Compliant

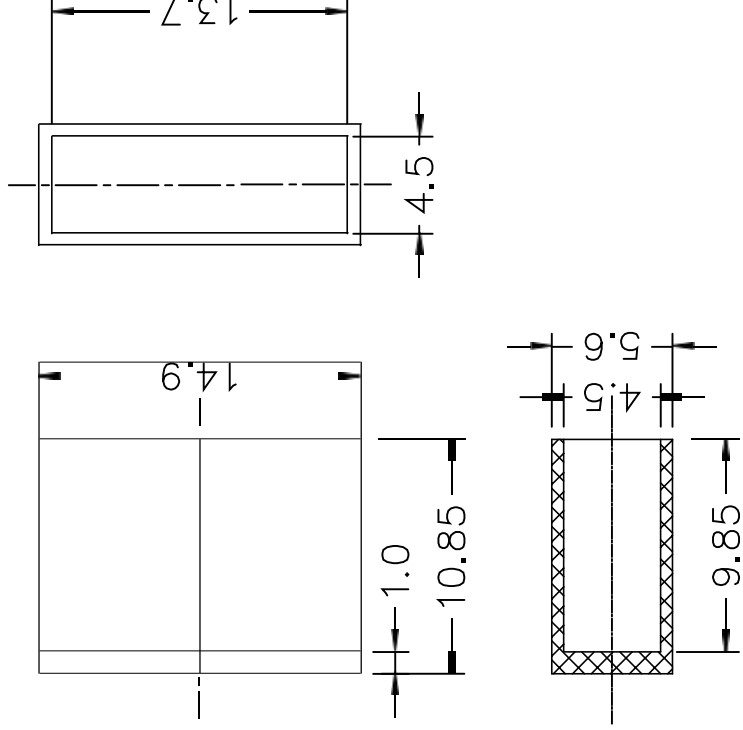

产品材质: LD-PE

图号 (DWGNO)	DYH-010	单位 (UNIT):	MM
版次 (REV):	A1	比例 (SCALE)	1:1
页次 (PAGE):	1/1	公差	未注公差
设计 (DESIGN):	Alan Tang	TOLERANCE UNINSPIRED	XX #0.15 XXX #0.1 X #5 XX #2
核准 (APPROVED):	唐估林	料号 (PART NO)	HDM1A公防尘帽 (不分边)
日期 (DATE):	2021/11/30		

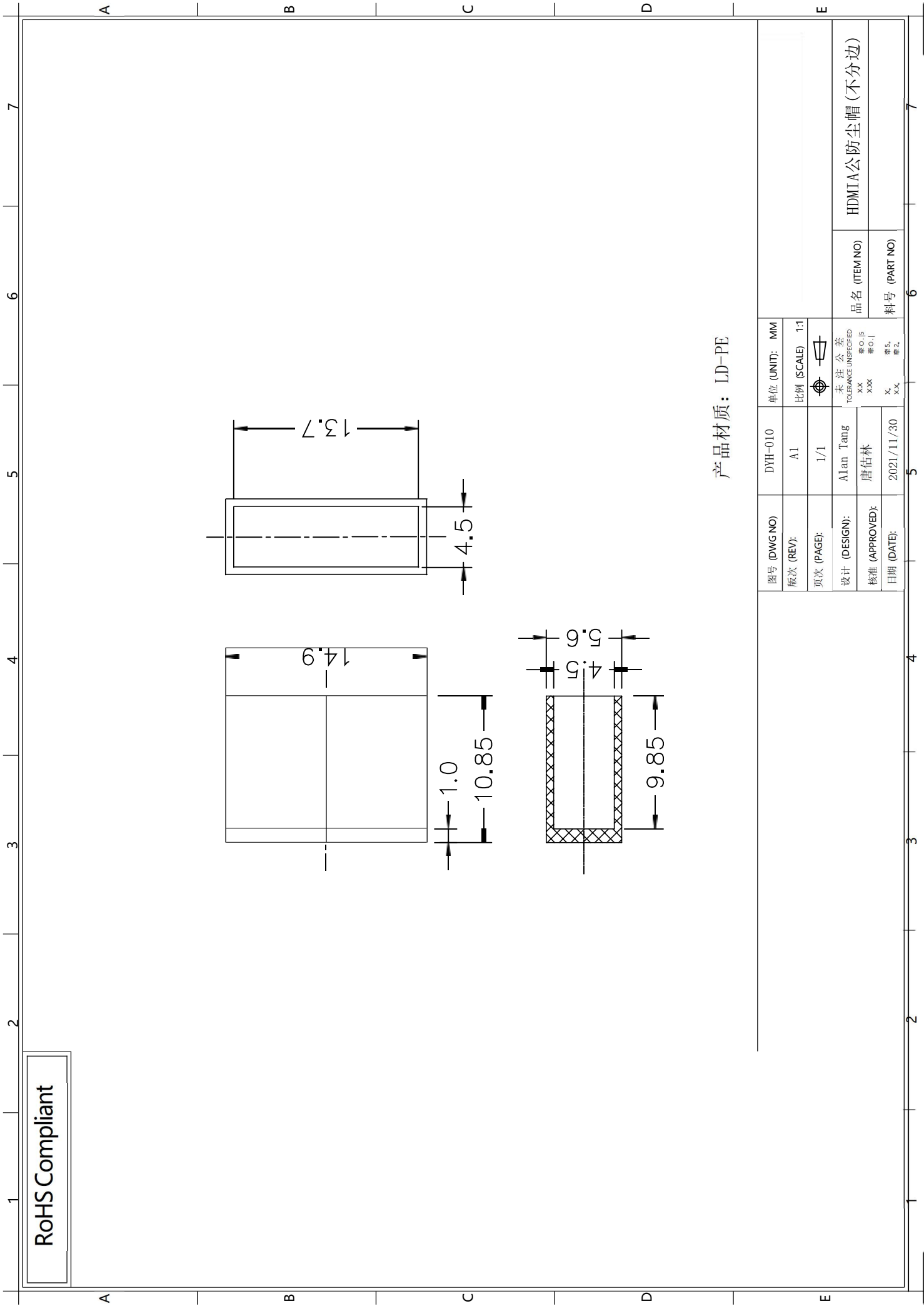

盐水喷雾试验报告

试验方法 METHOD	盐水喷雾腐蚀试验法 NEUTRAL SALT SPRAY CORROSION TEST	参考资料 REF	MIL-STD- 1344
客户		试验日期 DATE	2022.08.31
样品名称 SPECIMEN	HDMI 公/铜壳/铁壳	试验数量 (件) QTY	各5PCS

试验条件 (TEST CONDITION) :

1、盐水溶液 (SALT SOLUTION) : 浓度 50 ± 10 g/L, PH值6.5-7.2。

2、试验室温度 (TEMP. IN THE SPRAY CHAMBER) : 35 ± 1 °C。

3、盐水桶温度 (TEMP. OF SALT SOLUTION TANK) : 35 ± 1 °C。

4、压力桶温度 (TEMP. OF AIR SUPPLY) : 47 ± 1 °C。

5、试验室相对湿度 (R. H. IN THE CHAMBER) : 85%。

6、压缩空气压力 (COMPRESSED AIR PRESSURE) : 1.00 ± 0.01 kg/cm²。

7、样品放置位置 (SPECIMEN SUPPORTED ANGLE) : 尼龙绳吊挂70° -90° 。

8、喷雾收集量 (COLLECT RATE OF SALT SOLUTION) : 1-2ml/ (8cm²hr)

9. 盐雾测试时间: 36H

判定方法 (ADJUDGEMENT METHOD)

试验后以20倍放大镜观察、无蓝、绿色腐蚀物之现象, 即判定合格。 (Inspect the specimen at 20x magnification, no blue or green corrosion products are acceptable.)

实验料号	试验后现象 PHENOMENON AFTER TEST	判定 COMMENT
HDMI公/铜壳/铁壳	产品表面无变色, 无刮伤, 无脱皮	OK
主管 SUPERVISOR		试验员 TEST BY

深圳市创新胜为科技有限公司

Insertion and Withdrawal Test

插拔力测试报告

NO.报告编号: MZ_QC_2022831A001

Sample name 样品名称	HDMI 2.0 A TO A 30AWGOD:7.0mm L:1.0/ 1..5/2M/3.0M/5M Black	Sample Q'ty 样品数量	5PCS	Test date 测试日期	2022/8/31
Supplier 供应商名称		Part/No. 产品料号		Drawing NO. 工程图号	/
Product spec. 产品规格	HDMI 2.0 A TO A 30AWGOD:7.0mm L:1.0/ 1..5/2M/3.0M/5M Black				
Test machine 测试设备	Full-automatic Insertion and Withdrawal test machine 插拔力全自动试验机 MZ-CEJ043			Test environment 测试环境	温度: 32℃/ 湿度: 75%
Test Item 测试项目	Insertion / Withdrawal Force Test 插拔力测试				

Test Requirement 测试要求

1. Low Level Contact Resistance (20mV < 10mA) Initial: Contact: 10mΩ(max.) Shell:10mΩ(max.) After test :Contact :Change from initial value: 30 milliohms maximum. After test :Shell :Change from initial value: 50 milliohms maximum.
低电平接触阻抗测试(20mV < 10mA),原始阻抗: 10mΩ(max.), 外壳: 10mΩ(max.), 测试后, 接触PIN接触阻抗30mΩ(max.), 外壳50mΩ(max.)
2. Insertion and withdrawal speed : 25 mm/minute. 插拔速度25 mm/分钟;
3. Automatic cycling : 5000 cycles at 200 ± 50 cycles per hour Insertion force:44. 1N {5.5kgf} maximum
Withdrawal force: 9.8N { 1.0kgf} minimum ,39.2N {4.0kgf} maximum
自动插拔次数5000次, 在150次到250次时插入力44. 1N {4.5kgf}最大, 拔出力9.8N { 1.0kgf} 最小 ,39.2N {4.0kgf} 最大
4. After test,conduction ristance: 3Ω max. insulation ristance: 10MΩ min. 测试后, 导通阻抗 ≤ 3 Ω , 绝缘阻抗 ≥ 10MΩ;

Result of measurement 测试结果

1. L.L.C.R.传导阻抗(mΩ)

Sample	Pin No.	1	2	3	4	5	6	7	8	9	10	11	12	13	14	15	16	17	18	19	Shell	C.R.	I.R.	Judgement
1#	Ri	6.5	7.1	6.5	7.3	6.7	6.5	6.8	6.9	6.8	6.5	7.1	6.5	6.5	6.8	6.5	7.1	6.5	6.5	7.0	5.6	<3Ω	10MΩ	OK
	Rf	8.5	8.9	8.1	8.2	8.2	8.3	8.2	8.3	8.3	8.7	7.9	8.9	7.9	8.9	8.7	8.9	8.1	8.7	9.0	6.8	<3Ω	10MΩ	OK
2#	Ri	6.5	7.1	6.5	7.3	6.7	6.5	6.8	6.9	6.8	6.5	7.1	6.5	6.5	6.8	6.5	7.1	6.5	6.5	7.0	5.6	<3Ω	10MΩ	OK
	Rf	8.5	8.9	8.1	8.2	8.2	8.3	8.2	8.3	8.3	8.7	7.9	8.9	7.9	8.9	8.7	8.9	8.1	8.7	9.0	6.8	<3Ω	10MΩ	OK
3#	Ri	6.5	7.1	6.5	7.3	6.7	6.5	6.8	6.9	6.8	6.5	7.1	6.5	6.5	6.8	6.5	7.1	6.5	6.5	7.0	5.6	<3Ω	10MΩ	OK
	Rf	8.5	8.9	8.1	8.2	8.2	8.3	8.2	8.3	8.3	8.7	7.9	8.9	7.9	8.9	8.7	8.9	8.1	8.7	9.0	6.8	<3Ω	10MΩ	OK
4#	Ri	6.5	7.1	6.5	7.3	6.7	6.5	6.8	6.9	6.8	6.5	7.1	6.5	6.5	6.8	6.5	7.1	6.5	6.5	7.0	5.6	<3Ω	10MΩ	OK
	Rf	8.5	8.9	8.1	8.2	8.2	8.3	8.2	8.3	8.3	8.7	7.9	8.9	7.9	8.9	8.7	8.9	8.1	8.7	9.0	6.8	<3Ω	10MΩ	OK
5#	Ri	6.5	7.1	6.5	7.3	6.7	6.5	6.8	6.9	6.8	6.5	7.1	6.5	6.5	6.8	6.5	7.1	6.5	6.5	7.0	5.6	<3Ω	10MΩ	OK
	Rf	8.5	8.9	8.1	8.2	8.2	8.3	8.2	8.3	8.3	8.7	7.9	8.9	7.9	8.9	8.7	8.9	8.1	8.7	9.0	6.8	<3Ω	10MΩ	OK

2.Mating&Unmating Force 插入拔出力(Kgf)

	Initial (始)					Final (终)				
Insertion Force	2.1	2.2	2.0	2.1	2.3	1.8	1.8	1.7	1.6	1.7
Withdrawal Force	1.8	1.7	1.7	1.8	1.7	1.5	1.5	1.5	1.4	1.5
Judgement	OK									

3.Visual Inspection 外观检验

	Initial (始)	Final (终)
Result	1. Dimension: OK	
	2. No appearance defects	
Judgement	OK	

Judgement 综合判定	<input checked="" type="checkbox"/> PASS 合格 <input type="checkbox"/> NG 不合格
Note备注	According to ANSI/EIA-364- 13

Approval 核准: 郑峰

Checked 审核: 杨培荣 丁晟

Producer 制作: 陈小青

深圳市创新胜为科技有限公司
Cycle Bending Test Report

摇摆测试报告

NO.报告编号: MZ_QC 20220831A001

Product name 产品名称	HDMI 2.0 A TO A30AWG OD:7.0mm L:1.0/ 1..5/2M/3.0M/5M Black	Sample Q'ty 样品数量	10PCS	Test date 测试日期	2022/8/31
Customer 客户名称		Part/No. 产品料号	/	Drawing NO. 工程图号	/
Product spec. 产品规格	HDMI 2.0 A TO A30AWG OD:7.0mm L:1.0/ 1..5/2M/3.0M/5M Black				
Test machine 测试设备	Cycle Bending Test machine DJS-EN61 循环摇摆测试机:MZ-CS-037			Test environment 测试环境	温度: 36℃/ 湿度: 75%
Test Item 测试项目	Cycle Bending Test 循环摇摆测试				
Test Requirement 测试要求					
<p>1. Angle: ±60°摇摆角度: ±60度, Bending speed: 30Cycles/min, 摇摆速度: 30次/分钟, Bending cycles: 1500 Cycles 摇摆次数: 1500次, Bending Load: 300g, 荷重: 300g</p> <p>2. Fixed wire or outer mold to the center position of clamp, load 300g weights in the wire 30CM line, swing by setting the number and speed, After this, do a conduction test. DC: 300V/ 10ms, Insulation resistance 10MΩ min, Conduction need less than 3Ω max. 将线材或外模固定于夹具中心位置, 于线材30CM处系300g砝码, 按设定次数和速度进行摇摆; 完成后进行导通测试, DC: 300V/ 10ms, 绝缘阻抗10 MΩ 最小, 导通小于3Ω 最大。</p> <p>3. After test, connect the cable to the HD-TV and Blue-ray DVD, do a AV test, Resolution of 3840*2160P; 摇摆测试后, 将蓝光DVD与高清电视用测试线相连接, 做一个影音测试, 分辨率: 3840*2160P;</p>					
Result of measurement 测试结果					
1. Test diagram 测试图示					
<p>■ 正负60度摇摆</p>			<p>□ 正负90度摇摆</p>		
2. Test result 测试结果					
Sample No. 样品编号	Test result description 结果描述			Judgement 判定	
	DC 300V/0.01s CR ≤ 3Ω IR ≥ 10MΩ	Test Cycles 测试次数	3840*2160P AV Test 影音测试	OK	
1#	Match condition 符合条件	1500 Cycles	No snow, flicker, 无雪花、闪烁	OK	
2#	Match condition 符合条件	1500 Cycles	No snow, flicker, 无雪花、闪烁	OK	
3#	Match condition 符合条件	1500 Cycles	No snow, flicker, 无雪花、闪烁	OK	
4#	Match condition 符合条件	1500 Cycles	No snow, flicker, 无雪花、闪烁	OK	
5#	Match condition 符合条件	1500 Cycles	No snow, flicker, 无雪花、闪烁	OK	
6#	Match condition 符合条件	1500 Cycles	No snow, flicker, 无雪花、闪烁	OK	
7#	Match condition 符合条件	1500 Cycles	No snow, flicker, 无雪花、闪烁	OK	
8#	Match condition 符合条件	1500 Cycles	No snow, flicker, 无雪花、闪烁	OK	
9#	Match condition 符合条件	1500 Cycles	No snow, flicker, 无雪花、闪烁	OK	
10#	Match condition 符合条件	1500 Cycles	No snow, flicker, 无雪花、闪烁	OK	
Judgement 综合判定					
<p>■ PASS 合格 □ NG 不合格</p>					
Note 备注					
According to 参考UL-817标准/DKBA 6338 -2012.081 家庭终端 桌面产品可靠性试验技术规范V1.0					

Approval 核准: 郑峰

Checked 审核: 杨培荣 丁晟

Producer 制作: 陈小青

深圳市创新胜为科技有限公司

FULL-HD Display Test Report

影音测试报告

NQ 报告编号: MZ-QC-20220831A001

Product name 产品名称	HDMI 2.0 A TO A 30AWGOD:7.0mm L:1.0/ 1.5/2M/3.0M/5M Black	Sample Q'ty 样品数量	10PCS	Test date 测试日期	2022/8/31
Customer 客户名称		Part/No. 产品料号	/	Drawing NO. 工程图号	/
Product spec. 产品规格	HDMI 2.0 A TO A 30AWGOD:7.0mm L:1.0/ 1.5/2M/3.0M/5M Black				
Test machine 测试设备	3070ti测试主机 ROG 43寸显示器HDMI 2.0接口 4K测试显示仪			Test environment 测试环境	温度: 36℃/ 湿度: 78%
Test Item 测试项目	FULL-HD Audio & Video play Test 全高清影音播放测试				
Test Requirement 测试要求					
<p>1.Connected tested cable and DVD, HD-TV , if screen normal play ,it is connected properly 将待测线材与DVD、HD-TV进行连接,待画面正常播放方为连接正常.</p> <p>2.Audio and video playback need 5- 10S no snow, flicker, card dish phenomenon, sound playback smooth; 影音播放5- 10S无雪花、闪烁、卡碟等现象,声音播放流畅;</p> <p>3. When testing, the resolution is 3840*2160P on TV surface; 当测试时,电视界面会显示3840*2160P分辨率60hz;</p>					
Result of measurement 测试结果					
1. Test diagram 测试图示					
					
2. Test result 测试结果					
Sample No.	Test result description 结果描述				Judgement判定
1#	3840*2160P Audio and Video synchronization, no card screen, flicker, mosaics				OK
2#	3840*2160P Audio and Video synchronization, no card screen, flicker, mosaics				OK
3#	3840*2160P Audio and Video synchronization, no card screen, flicker, mosaics				OK
4#	3840*2160P Audio and Video synchronization, no card screen, flicker, mosaics				OK
5#	3840*2160P Audio and Video synchronization, no card screen, flicker, mosaics				OK
6#	3840*2160P Audio and Video synchronization, no card screen, flicker, mosaics				OK
7#	3840*2160P Audio and Video synchronization, no card screen, flicker, mosaics				OK
8#	3840*2160P Audio and Video synchronization, no card screen, flicker, mosaics				OK
9#	3840*2160P Audio and Video synchronization, no card screen, flicker, mosaics				OK
10#	3840*2160P Audio and Video synchronization, no card screen, flicker, mosaics				OK
Judgement 综合判定					
<input checked="" type="checkbox"/> PASS 合格 <input type="checkbox"/> NG 不合格					
Note备注					

Approval 核准: 郑峰

Checked 审核: 杨培荣 丁晟

Producer 制作: 陈小青

8

7

6

5

4

3

2

1

E

E

D

D

C

C

B

B

A

A

技术要求:

1. 材质: K=K 打钉
2. 外尺寸420*380*330CM
3. 公差: $\pm 3\text{mm}$
4. 印刷:
5. 边压强度: $\geq 5000\text{N/M}$;耐破强度: $\geq 13\text{KGf/CM}^2$;
(以上数值为成品任一测试要求, 非平均值)
6. 接合方式: 打钉;
7. 上下翻页尺寸按照0201箱型计算;
8. 无爆线 脱坑 见坑现象;
9. 裁切边角整齐, 无毛刺及水纸更改现象;
10. 印刷清晰完整, 无露白, 表面整洁;
11. 所有材质符合RoHS规范;

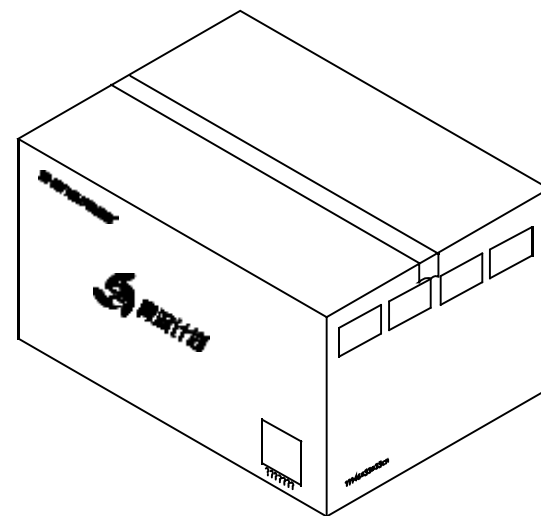

11				
10				
9				
8				
7			1/X	SET
6			1/X	SET
5			1/X	SET
4			1	SET
3			1	SET
2			3/1 5/1 10/1	SET
1	纸箱尺寸	420*380*320mm	1	SET
ITEM	NAME	DESCRIPTION	QTY	UNIT

X,± 1 X,*± 1

.X± 0.3 .X*±

.XX± 0.20 .XX*±

.XXX± 0.100 .XXX*±

UNITS: mm

TEST DRAWINGS AND SPECIFICATIONS ARE THE PROPERTY OF WIDER CABLE AND SHALL NOT BE REPRODUCED COPIED OR CUED IN ANY MANNER WITHOUT THE PRIOR WRITTEN CONSENT OF WIDER CABLE.

Customer P/N:

中山市美芝电线电缆有限公司

DOCUMENT NO.:

TITLE:
ADD DP1.2 1.0M 1.5M 3.0M

APPD:

Customer Name: 胜为

CHKD:

DRAW: wanlvxiao

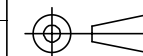

SCALE	Pages	RCV
1:1	2/2	A

8

7

6

5

4

3

2

1